

RESOLUTION NO. 24556

A RESOLUTION AUTHORIZING HEIDI HEFFERLIN TO USE TEMPORARILY THE CITY RIGHTS-OF-WAY ALONG THE 1800 BLOCK OF COWART STREET AND THE 200 BLOCK OF WEST 18TH STREET TO INSTALL STAIRS AND ELECTRICAL METERS INTO THE CITY'S RIGHTS-OF-WAY, AS SHOWN ON THE DRAWINGS ATTACHED HERETO AND MADE A PART HEREOF BY REFERENCE, SUBJECT TO CERTAIN CONDITIONS.

BE IT RESOLVED BY THE CITY COUNCIL OF THE CITY OF CHATTANOOGA, TENNESSEE, That Heidi Hefferlin (hereinafter referred to as "Temporary User") be and is hereby permitted to use temporarily the City rights-of-way along the 1800 block of Cowart Street and the 200 block of West 18th Street to install stairs and electrical meters into the City's rights-of-way, as shown on the drawings attached hereto and made a part hereof by reference.

BE IT FURTHER ORDAINED, That said temporary usage shall be subject to the following additional conditions:

1. Temporary User shall execute the Indemnification Agreement attached hereto in favor of the City of Chattanooga, its officers, agents and employees for any and all claims for damages for injuries to persons or property related to or arising out of the temporary usage.
2. Temporary User agrees to vacate the property and temporary use upon reasonable notice from the City to do so.
3. Temporary User shall provide adequate access for maintenance of any utilities located within the easement.

ADOPTED: September 27, 2005

INDEMNIFICATION AGREEMENT

This Indemnification Agreement is entered into by and between THE CITY OF CHATTANOOGA, TENNESSEE (hereinafter the "City"), and HEIDI HEFFERLIN (hereinafter "Temporary User"), this 27 day of September, 2005.

For and in consideration of the granting of the temporary usage of the City rights-of-way along the 1800 block of Cowart Street and the 200 block of West 18th Street to install stairs and electrical meters into the City's rights-of-way, as shown on the drawings attached hereto and made a part hereof by reference, the receipt of which is hereby acknowledged, Temporary User agrees as follows:

1. Temporary User will defend, and hold harmless the City of Chattanooga, Tennessee, its officers, agents and employees from any and all claims for damages for injuries to persons or property related to or arising out of the aforementioned temporary use.

2. Temporary User will vacate the property and temporary use upon reasonable notice from the City to do so; the parties hereto agree that "reasonable notice" shall be deemed to be thirty (30) days. Temporary User will restore the property to its original condition when it is returned to the City.

3. Temporary User will provide adequate access for maintenance of any utilities located within the easement.

HEIDI HEFFERLIN

BY: 

Oct. 10, 2005
Date

CITY OF CHATTANOOGA, TENNESSEE

BY: 

Oct 3, 2005
Date

Ron Littlefield, Mayor

/add

200 BLK S 181ST M

7 ACCESS STAIRS 181ST BREET TO WHYHOUSES

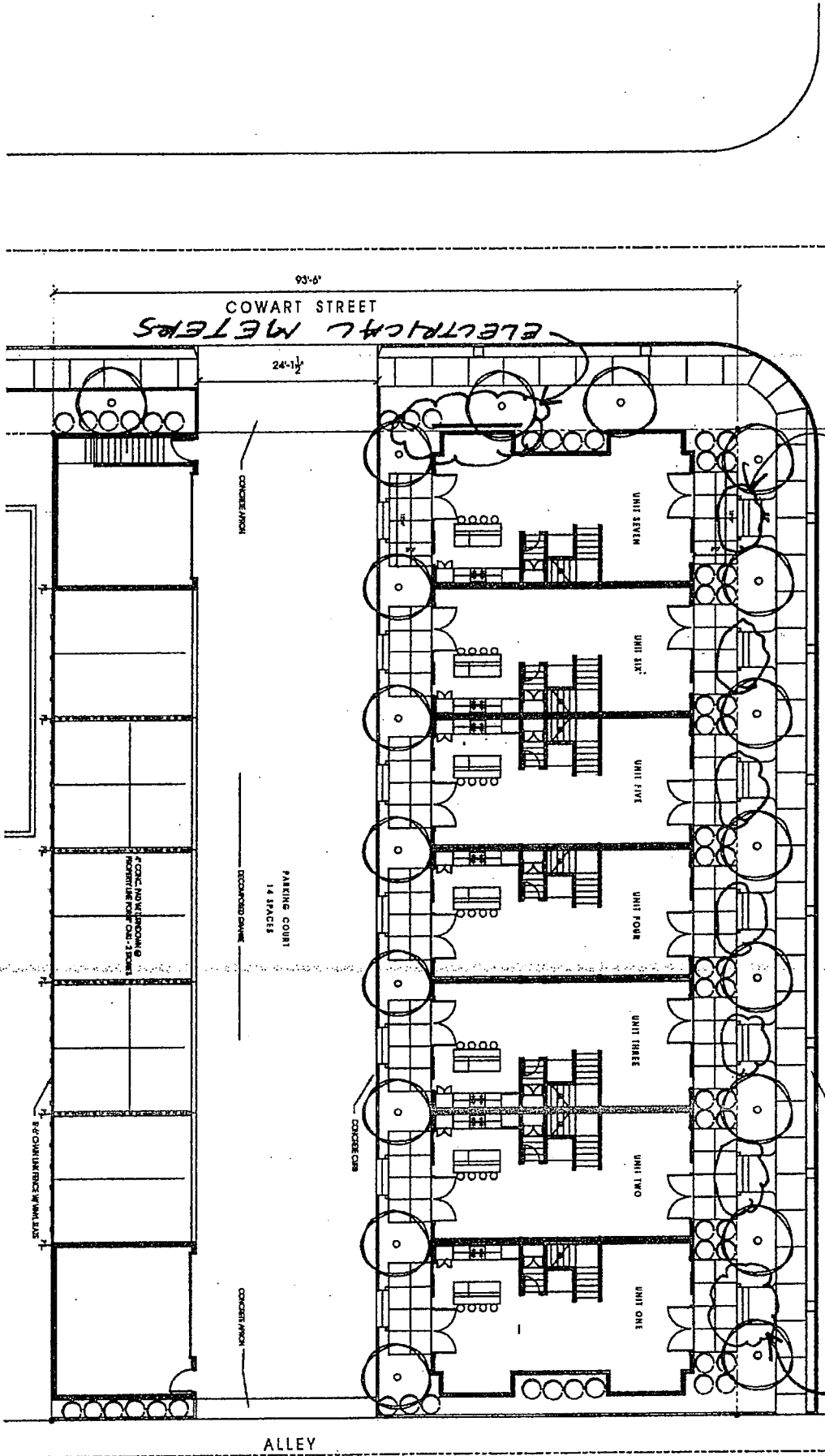

COWART STREET
ELECTRICAL METERS

93'-6"

156'-0"

CONCRETE PORCH

PARKING COURT
14 SPACES

DECONCRETE DRIVE

CONCRETE PORCH

ALLEY

8' 0" CHURCH STREET SIDE WALK

CONCRETE PORCHING & RECONSTRUCTION FOR 1.5' DEPTH

TEMPORARY USE PERMIT REQUEST
FOR TO WHYHOUSES @ 1800 COWART ST
FOR ACCESS STAIRS AND ELECTRICAL METERS
1st 20'
8.30.5

HEFFERLIN + KRONENBERG
ARCHITECTURE PLANNING INTERIOR DESIGN

TEMPORARY USE PERMIT REQUEST
 FOR TOWNHOUSES @ 1800 COWART
 FOR ACCESS STAIRS AND ELECTRICAL METERS
 1" = 10'-0"
 8.30.5

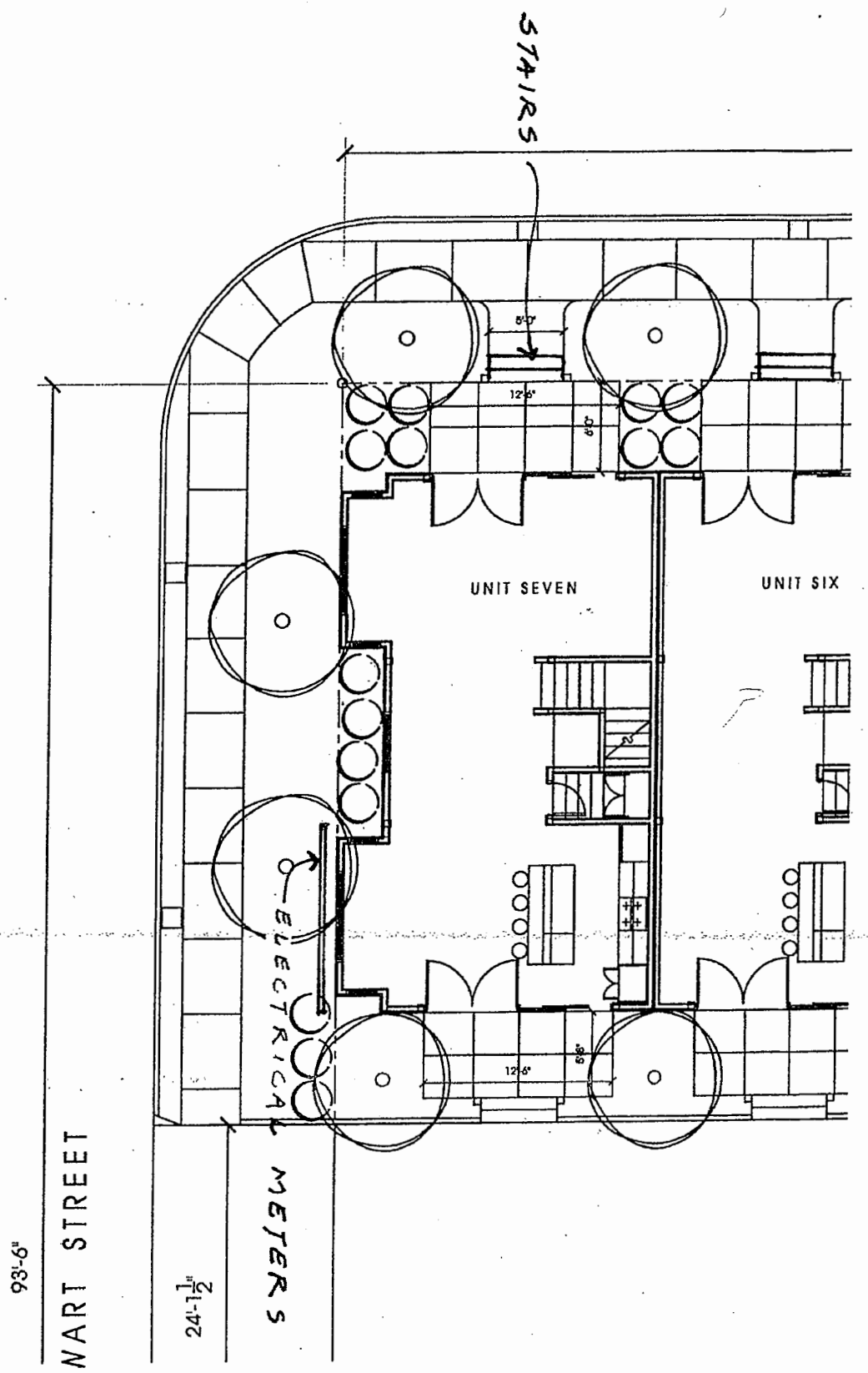

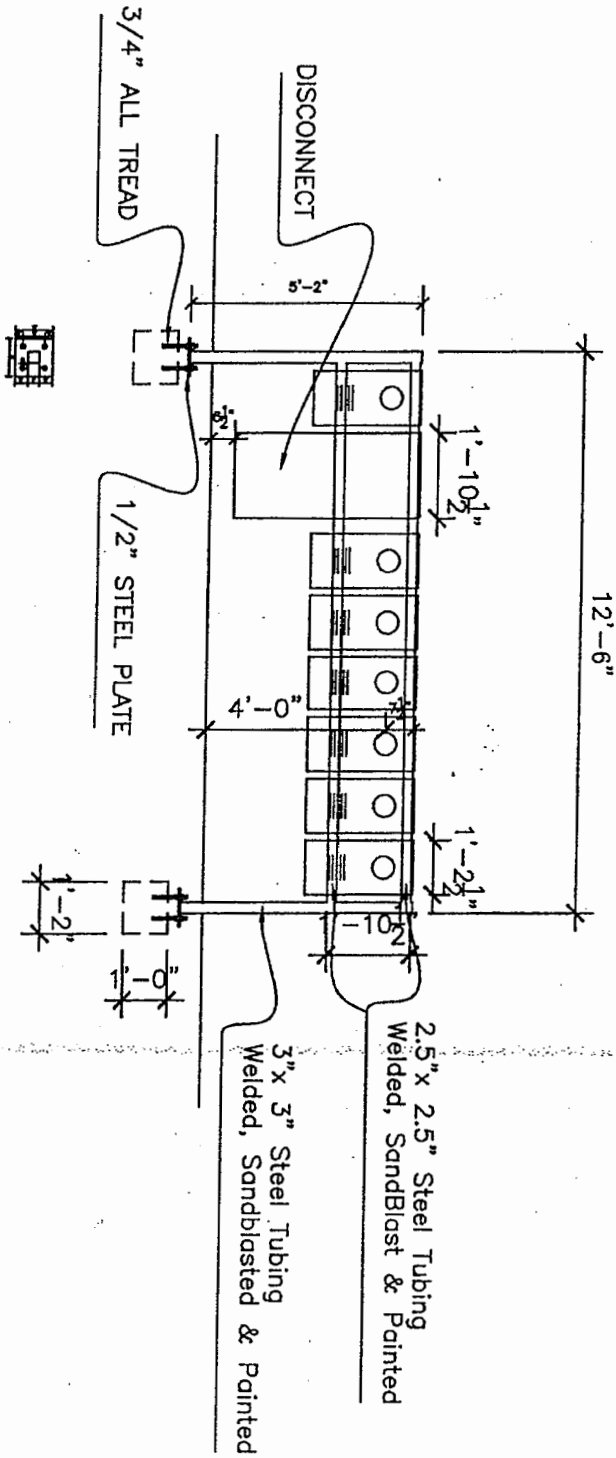
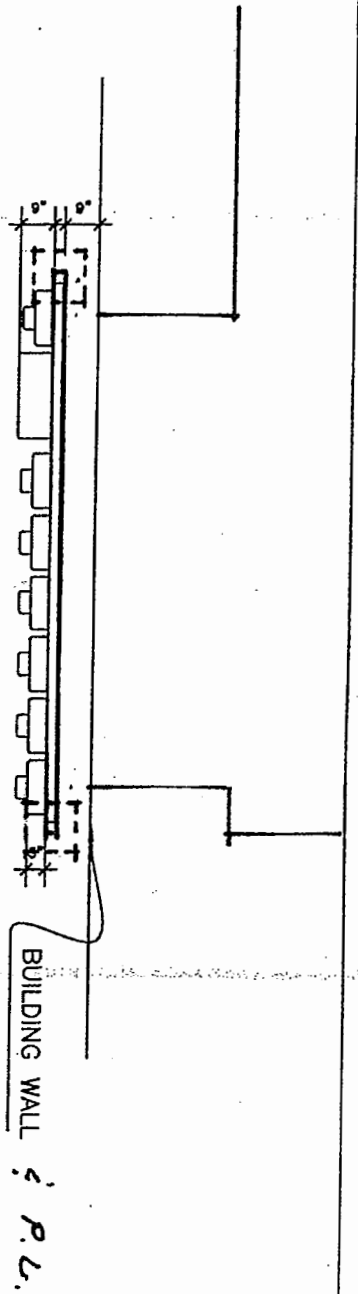

ELECTRICAL METERS
 1/4" = 1' 0"
 1800 COWART

HEFFERLIN + KRONENBERG
 ARCHITECTURE PLANNING INTERIOR DESIGN
 225 WEST MAIN STREET CHATTANOOGA, TN 37203